



tvmount

doubleswing

moreview
UPHOLDING
A VISION.®

Product Number:
DSNS13220CL

Supports Flat Panels up to 42" or 40 lbs.

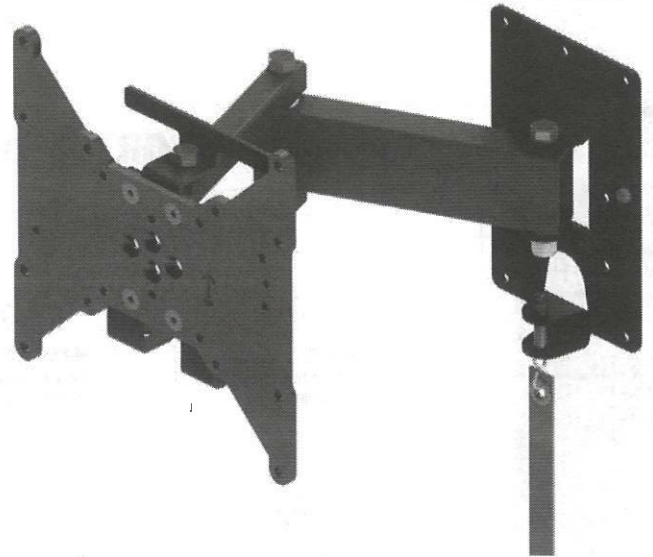
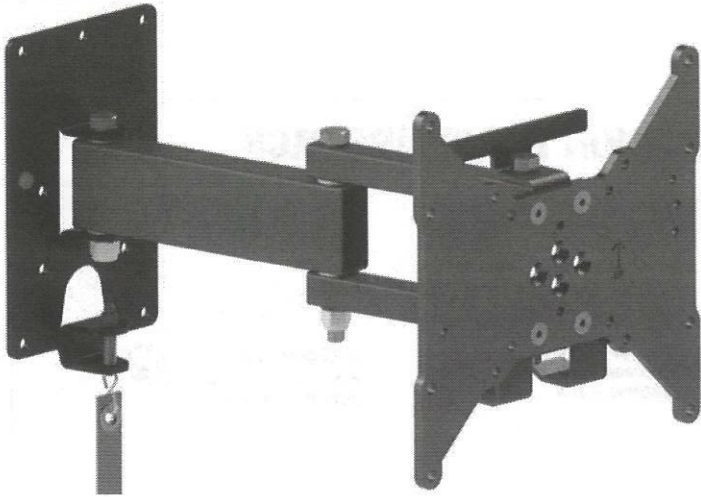

Product features:

- Double Swing and Pan combination offers many viewing angles
- Left and Right locking positions allows for greater mounting location versatility
- Lightweight and affordable design
- Wide mounting footprint to minimize mounting surface load

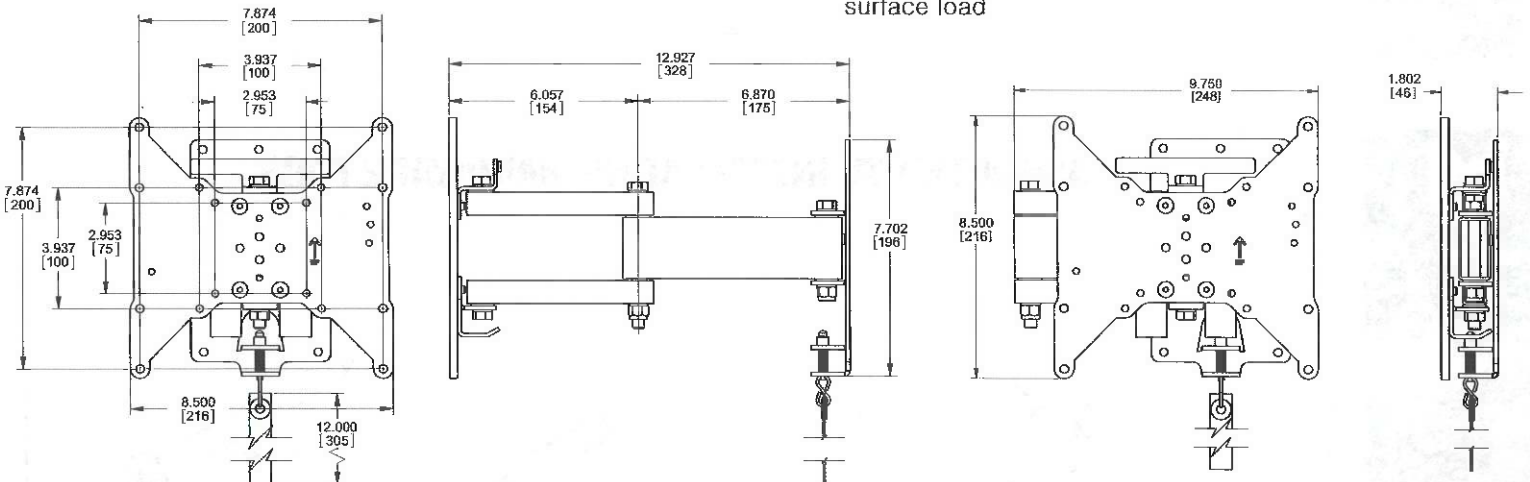

Product specifications:

Model: DSNS13220CL

**One Year Warranty - Minimal Assembly Required
Designed, Engineered, and Manufactured in USA**

	ENGLISH	(METRIC)
COMMON SCREEN SIZES:	19"-42"	(28.2 cm - 106.7 cm)
MAX LOAD:	40 lbs.	(18.1 kg)
HOLE PATTERN RANGE: (VESA)	3 X 3", 4 X 4", 4 X 7-7/8", 7-7/8 X 7-7/8"	(75 X 75mm, 100 X 100mm, 100 X 200mm, 200 X 200mm)
DIMENSIONS:	9-3/4" W X 8-1/2" H X 1-3/4" D	(24.8" W X 21.6" H X 4.4" D cm)
SHIPPING WEIGHT:	4.0 lbs	(1.8 kg)



2805 Frederic Dr. • Elkhart • Indiana • 46514

574.266.1455 www.ramco-eng.com

NOVEMBER 2018



moreview
UPHOLDING
A VISION.®

kit

installation

• vesa mounting fasteners
• wall mounting hardware

Product Number:
KIT-S2

ASSORTED TV INSTALLATION HARDWARE PACK



M412MMP (X4)
M4 X 12MM PHIL PAN
MACHINE SCREW



M416MMP (X4)
M4 X 16MM PHIL PAN
MACHINE SCREW



M420MMP (X4)
M4 X 20MM PHIL PAN
MACHINE SCREW



1240APP (X2)
#12 X 2-1/2" PHIL PAN
SHEET METAL SCREW



M620MMP (X4)
M6 X 20MM PHIL PAN
MACHINE SCREW

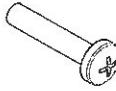

M630MMP (X4)
M6 X 30MM PHIL PAN
MACHINE SCREW

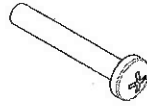

M640MMP (X4)
M6 X 40MM PHIL PAN
MACHINE SCREW



NYL173125 (X4)
.2 X .3 X .3 NYLON SPACER



moreview
UPHOLDING
A VISION.®

kit

installation

• wall mounting hardware

Product Number:
KIT-S3

ASSORTED TV INSTALLATION HARDWARE PACK

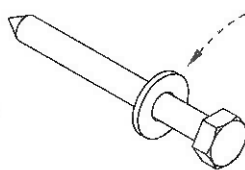

1440LAGB (X2)
1/4 X 2-1/2"
LAG SCREW - BLACK

+

14WSAEB (X2)
1/4 SAE FLAT WASHER
BLACK - FOR LAG SCREW

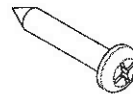

1220APP (X6)
#12 X 1-1/4" PHIL PAN
SHEET METAL SCREW

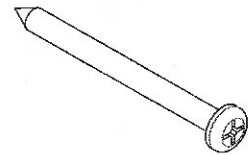

1240APP (X2)
#12 X 2-1/2" PHIL PAN
SHEET METAL SCREW