



Idee in movimento...

EURO LOFT BED LIFT BY PROJECT 2000 OWNER'S MANUAL

by



LIPPERT
COMPONENTS™

TABLE OF CONTENTS

System and Safety Information	3
Target Readers	3
Purpose Of The Manual	3
Compliance With Current Legislation	3
Manual Preservation	3
How To Obtain An Additional Copy Of The Manual	3
User Information	4
Manufacturer's And Product Identification Data	6
Technical Features	6
Environmental Features	6
Movement and Transport	6
Prior to Installation	7
Installation	7
Mechanical	7
Electrical	8
Mechanical Encoder	9
Circuit Board Connection	9
Assembling and Harnessing Procedure for the Encoder Unit	9
Security and Safety Devices	14
Unauthorized Access	14
Warning Status for Safety Lock	14
Motor Protection System	14
Start-Up and Testing	15
Application Field and Purpose	15
Important Information	15
Maintenance	15
Maintenance Operations	16
Disassembling and Demolition	16
General Information On Safety Regulations	17
Warranty Terms And Conditions	17
Bed Lift Maintenance Log	19

System and Safety Information

This manual will enable you to know and use your Euro Loft bed lifting system .

Please read the manual carefully before using the system.

The manual was written for users and/or product maintenance technicians and it is an integral part and of the product.

This manual provides information for a correct and proper use and maintenance of the bed lifting system, as well as instructions to protect operators.

Target Readers

Target readers of this manual are users and technicians in charge of transport, installation, use, surveillance, maintenance and final disassembling of the system.

Purpose Of The Manual

This manual describes the system purpose and use based on its project and technical features; it provides instructions for transport, proper and safe installation, mounting, adjustment and use. It provides information for maintenance operations, it simplifies spare part order placement procedures and provides insight on possible residual risks.

Compliance With Current Legislation

Specific legislation related to work accident prevention must be complied with, as well as the guidelines provided in this manual.

Manual Preservation

This manual is an integral part of the system and must be preserved until system final disposal.

The manual must be preserved in a safe and dry environment, protected against UV-rays and it must be available at hand near the machine.

How To Obtain An Additional Copy Of The Manual

If this copy of the manual is damaged, a new copy can be requested to the manufacturer at the requesting customer's own expense.

User Information

1. This manual reflects the state of the art for the machine and cannot be considered unsuitable due to any possible updates related to new experiences.
2. The manufacturer reserves the right to update production processes and manuals without the obligation to update previous production processes and manuals.
3. The features of the materials used may be changed at any time, due to technical development, without previous notice.
4. The manufacturer shall be held harmless from any possible consequence of:
 - Improper use of the system.
 - Use by unauthorized staff.
 - Use in breach of the guidelines provided in this manual.
 - Use in breach of current laws and regulations.
 - Use in case of primary power defects.
 - Use with serious maintenance negligence.
 - Use in breach of the maximum capacity values indicated in this manual.
 - Use without safety fall-protection equipment.
 - Use with unauthorized changes or modifications, unless approved in advance by the manufacturer in writing.
 - Use with non original spare parts or spare parts which were not specifically designed for the model.
 - Use in partial or total breach of the instructions provided in this manual.
 - Use when the vehicle is running.
5. The general warranty shall expire in case of:
 - Bad preservation.
 - Problems due to wrong installation.
 - Improper or unskilled use.
 - Overcoming performance limits.
 - Undue mechanical and/or electric stress.
 - Use in conditions described at par. 4.



BED LIFTING SYSTEMS, as well as all other devices with operating components, may cause death, serious injury or property damage if improperly used and/or protected.

The user shall guarantee that:

All transport, connection, maintenance and repair operations are carried out by skilled and authorized staff.

Skilled staff is understood as being (pursuant to IEC 364) the staff whose training, education, experience, information on law and regulations, accident prevention measures and terms of use and service, and who is able to carry out necessary operations recognizing and avoiding any possible danger and/or damage.

All necessary instructions and information are available to the staff.

The manual must be preserved throughout the whole bed lifting system life and must be handed on to new users or owners.

The information provided in this manual does not replace safety regulations and technical specifications for installation and operation which directly apply to the product and its packaging.

This manual is intended to reflect the current state of the art in technique and shall not be considered unsuitable due to future updates based on new experiences.

The Manufacturer reserves the right to change the manual without incurring any obligation to update previous versions.

An improper use of the bed lifting system or use different from what described in this manual will automatically invalidate any warranty term or Manufacturer's responsibility. The system shall be used by responsible and adult staff.

It is necessary to carefully preserve this manual, as the Manufacturer shall not be held liable for any damage to person or property or to the bed lifting system if this was used in an improper or unskilled way, other than described in this manual or in case of non-compliance with maintenance and safety rules.

Product knowledge and compliance with the instructions provided in these documents are prerequisite to ensure safety requirements and proper functioning.

It is therefore necessary to keep strictly to the following instructions.

In case of any problem or failure - unless it is to be considered as routine maintenance - it is necessary to contact our "Customer Service Department" in order to avoid any possible changes affecting product safety, reliability and function.

However, any operation on the product shall be carried out by skilled and authorized staff.

Our bed lifting systems were designed and manufactured in compliance with current 2006/42/EC directive and UNI EN 1646-1 regulation.

No safety device may be removed or changed by the Purchaser: the Manufacturer shall be held harmless in case of breach of the aforementioned rule.

Any change not affecting installed products existence or efficiency shall however be subject to the Manufacturer's approval and to tests by bodies responsible for testing, according to the current standards, at the Purchaser's own responsibility and expenses.

The Manufacturer provides a 2-year warranty against manufacturing defects for the bed lifting system components.

This manual shall always be available to the user and/or maintenance technician, who shall always be informed about the correct use of the product and about any possible residual risks.

It must be preserved in a dry, clean environment protected against heat.

Always use the manual so to protect it against partial or total damage.

Do not erase, tear or rewrite its content for any reason. In case of loss of the manual or if further information is required, please contact your area retailer or the manufacturer.

Manufacturer's And Product Identification Data

MANUFACTURER: Project 2000 S.r.l. – Via Vivaldi, 40/A – IT 50041 Calenzano (FI) – VAT an tax No. 05025550483

BED LIFTING SYSTEM SERIES 12600

Technical Features

Always refer to the identification plate on the product.

Environmental Features

Feature	Value	Unit
Operating temperature	-10 - 60	°C
Storage temperature	-20 - 70	°C
Storage moisture level	90	%
Environmental operating moisture level	90	%
May be damaged by water due to condensation		
Maximum storage time for board: 10 years		

Movement and Transport

The product is dispatched in perfect operating conditions after being tested at our premises.

Packaging type:

- If individually dispatched, the product is packed in a cardboard box.
- For multiple product deliveries, the bed lifting systems will be dispatched on adequately protected pallets.

Transport shall be carried out by a specialized company.

It is necessary to inform the Manufacturer of any possible damage upon arrival of the goods and to make sure the product is perfectly preserved and intact.

Make sure the system has no evident damage and the delivery is complete and write any possible problem on the shipping document and/or invoice.

If the damage is visible, preserve the packaging so that it can be viewed by the transport Company that delivered the system. Contact the transport Company immediately for a damage refund request.

If the delivery does not match with the order, contact the Manufacturer immediately.

Any damage or inconsistency must be communicated timely.

Any possible material inserted as product protection must be disposed of based on their specific features.

Packaging parts may cut, cause injuries or become dangerous if they are not handled with care or improperly used; keep out of reach of children and people who are not in charge of handling the system.

The system was not designed, manufactured and tested to operate in environments other than vehicles, with a high chemical gaseous materials pollution level, such as chlorine, ammonia and similar materials, in environments with a high fire and explosion risk or with a high electric risk.

However, bed lifting systems shall be transported by skilled and authorized staff.

Prior to Installation

All installation operations shall be carried out by skilled and authorized staff.

Remove the product from packaging.

Installation

Mechanical

NOTE: Always install the bed lifting system taking into account the system maximum load. THE BED UNIT AS A WHOLE - INCLUDING BED LIFTING SYSTEM, MATTRESS, PILLOW, BLANKETS, ETC. - MUST NOT WEIGH MORE THAN 60 KG.

NOTE: TAB. A AND TAB. B images are all located on Page 19 of this manual.

1. Place the system under the bed frame, following the layout example shown in TAB. A - Picture A.1, taking into account the motor revolution direction indicated by an arrow on the plastic support side (TAB. B - Picture B.1). The revolution direction stands for the winding direction of the belts. As a consequence, the shafts must have the same rotation direction.
2. It is very important that the belts winding in one direction are mounted in a parallel way on both shafts; the same applies to the belts winding in the opposite direction (TAB. B - Picture B.2)
3. After mounting the bed lifting system under the bed frame, wind the belts around the shafts taking care of the motor revolution direction and pre-wind the belts at least twice (TAB. B - Picture B.3)

NOTE: The four belts must be pre-wound at least twice around the shafts in the bed lowest position; the same applies to all of the four belts.

4. Place the four belt-fixing plates (TAB. A - Picture A.2) in a suitable position - i.e. the highest position the system will reach - making sure the belts are aligned with the runners and taking care of the minimum distance to be kept between the slider and the belt-fixing plate (TAB. A - Picture A.3) and making sure that it will bear the system maximum load.

NOTE: The bed lifting system can bear a total maximum weight of 400 kg.

5. Fix the belt-fixing plates with suitable screws (we recommend 4.2x25 screws) in the four slots first, in order to adjust and correct any possible installation defect and then fix all of the remaining screws (TAB. A - Picture A.2)
6. Place the bed frame inside of the vehicle on four temporary supports in order to keep it parallel to the vehicle floor. The temporary supports height must be measured based on the lowest position the bed will reach.
7. Insert the belts into the belt-fixing plates as illustrated in TAB. A - Picture A.2, stretch them and fix the four M6 bolts by cross-screwing, insert the covers into the belt-fixing plates.
8. Activate the bed lifting system and lift it to the maximum height wished; then make sure the belts are perfectly aligned with the belt sliders.
9. Place the two stabilizer runners by inserting them bottom-up into the stabilizers mounted on one side of the bed (TAB. A - Picture A.4).

NOTE: The runners must be mounted on the longest side of the bed and fixed on a suitable supporting bracket with suitable screws so that it will tolerate oscillations caused by the bed lifting system.

10. Fix one screw in the middle channel of the runner (we recommend at least 3.8x20 screws) on the highest position available under the stabilizer.

11. Place the limit switch correctly, making sure the bed locates against it perfectly when it comes to its highest position.

NOTE: For bed lifting systems where the highest position is right under the vehicle roof or when the highest position more than 1500 mm from the floor, it is necessary to mount at least 2 opposed safety belts with internal micro-switch with normally closed contact.

NOTE: The micro-switch must be connected in series with the limit switch. There must be at least 2 opposed safety belts.

12. Bring the bed lifting system to its lowest position, making sure the stabilizer runners are in a perfectly vertical position and will not jam.

13. Fix the stabilizer runners with suitable screws (we recommend at least 3.8x20 screws) in the middle channel of the runner at a maximum distance of 10" from each other.

NOTE: Make sure the screw head does not protrude too much, otherwise it will hit and damage the stabilizer. Adjust the stabilizer and fix the m4x6 screws with some "soft" thread-locker.

14. Then install the electrical components (Fig. 7) and program the system as illustrated in the installation and programming manual (ONLY AVAILABLE FOR SERVICE CENTERS)

NOTE: It is forbidden to use the bed while the vehicle is running, as the bed must be locked with safety belts.

NOTE: Each bed lifting system model was designed and developed to reduce or eliminate any risks related to cutting and tangling. The installer must however mount the system avoiding any risk factors/elements such as sharp edges, curls, etc.

15. After finishing installation, make sure the bed lifting system has no clearances and movements and the bed is parallel to the floor.

NOTE: In the event it is necessary to operate the bed lift system manually through the handle, it is compulsory to carry this operation without disconnecting the wires from the motor unit to the control unit.

NOTE: Never disconnect the wires from the motor unit to the control unit for a manual start of the bed lift system.

Electrical

- With mechanical encoder.

The circuit board is a controlling device with:

- DC 12 V power, maximum 25A.
- Free, normally closed contact end-of-stroke signal input.
- DC 12 V, maximum 25 A motor output, with polarity control.

Fig. 1

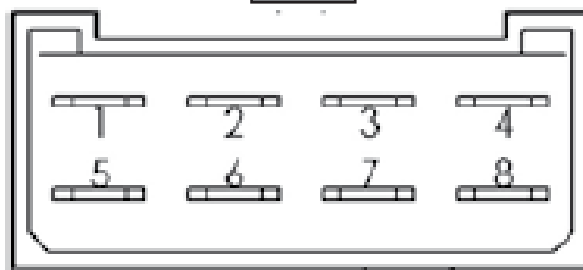

Mechanical Encoder

Circuit Board Connection

The circuit board is a controlling device equipped with:

- DC 12 V, 25A maximum

Working contact

- DC 12 V, 25 A maximum motor output with polarity control

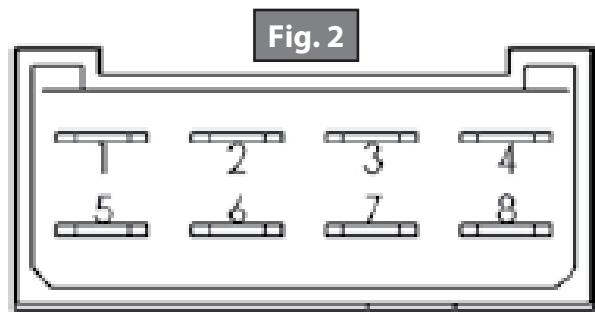

Silkscreen Printing	Logic ID	Range	Clamps	Description
CN1	GND	GND	CN1-8	Negative power post
	MOT2	DC 0-12 V	CN1-7	Motor (Grey)
		Not used	CN1-6	Not used
	F.C. (C-5)		CN1-5	End-of-stroke (C-5) (Orange)
	+12	DC 12 V	CN1-4	Positive power post
	MOT1	DC 0-12 V	CN1-3	Motor (Brown)
		Not used	CN1-2	Not used
	F.C. (C-4)		CN1-1	End-of-stroke signal (C-4) (Yellow)

Power	
DC Current Voltage (nominal)	DC 12 V
Tolerance	-10% / +20% *
DC Current Voltage (Minimum ÷ Maximum)	10.8 - DC 14.4 V

NOTE: *The value indicated takes into account average motor features and estimated work load. The value indicated here is the minimum value guaranteed for the system to work at maximum declared load. With reference to Fig. 2, voltage must be applied to clamps 4 and 8 of the 8-pole faston connector, making sure to connect the positive pole with the clamp and the ground to clamp 4.

Assembling and Harnessing Procedure for the Encoder Unit

Standard motor rotation (the belt shaft rotates in the direction shown by the arrow printed on the black plastic cover)

Connect the ORANGE wires to the “Down” end of stroke of the mechanical encoder and connect the YELLOW wires to the “Up” end of stroke.

Reverse motor rotation (the belt shaft rotates in the opposite direction shown by the arrow printed on the black plastic cover)

In the control panel, invert the orange wire and the yellow wire.

Connect the YELLOW wires to the “Down” end of stroke of the mechanical encoder and connect the ORANGE wires to the “Up” end of stroke.

1. While preparing the bed after pre-loading the belt by turning it twice around the shaft (and therefore after more or less setting the lowest position for the bed), place the mechanical encoder bracket and insert the threaded sleeve into the shaft. Check the shaft rotation when the bed is descending and consequently in which direction the anti-rotation tab is moving, place the end of stroke button on the “mechanical encoder” bracket on the side on which the “anti-rotation” tab is moving when the bed is descending and fasten it by tightening the 3 mm nut. Make sure that the sleeve on the shaft is fastened in the correct position and the “anti-rotation tab” has enough room inside of the encoder bracket slot to slide throughout the whole ascent of the bed and that the ring nut on the bolt has enough threading left to cover the bed ascent distance.

2. Move the bed upwards for a few centimeters, lower the bed and check the exact stop position: if it does not match the desired position, loosen the 14 mm bolt fastening the button and rotate the button to the extent that it is deemed necessary and try again to lift and lower the bed. Repeat the operation until the desired position is reached. Remember to fasten the 14mm bolt.

How to correctly check the end of stroke connection:

1. Control panel, by pressing the UP button the bed must go up and it must go down when pressing the DOWN button.
2. When pressing the end-of-stroke button while lifting the bed to the highest position, the bed must immediately stop.
3. Press the end-of-stroke button (the one mounted on the mechanical encoder) to set the lowest position while lowering the bed: the bed must immediately stop.

After doing this, check that the end of strokes are synchronized.

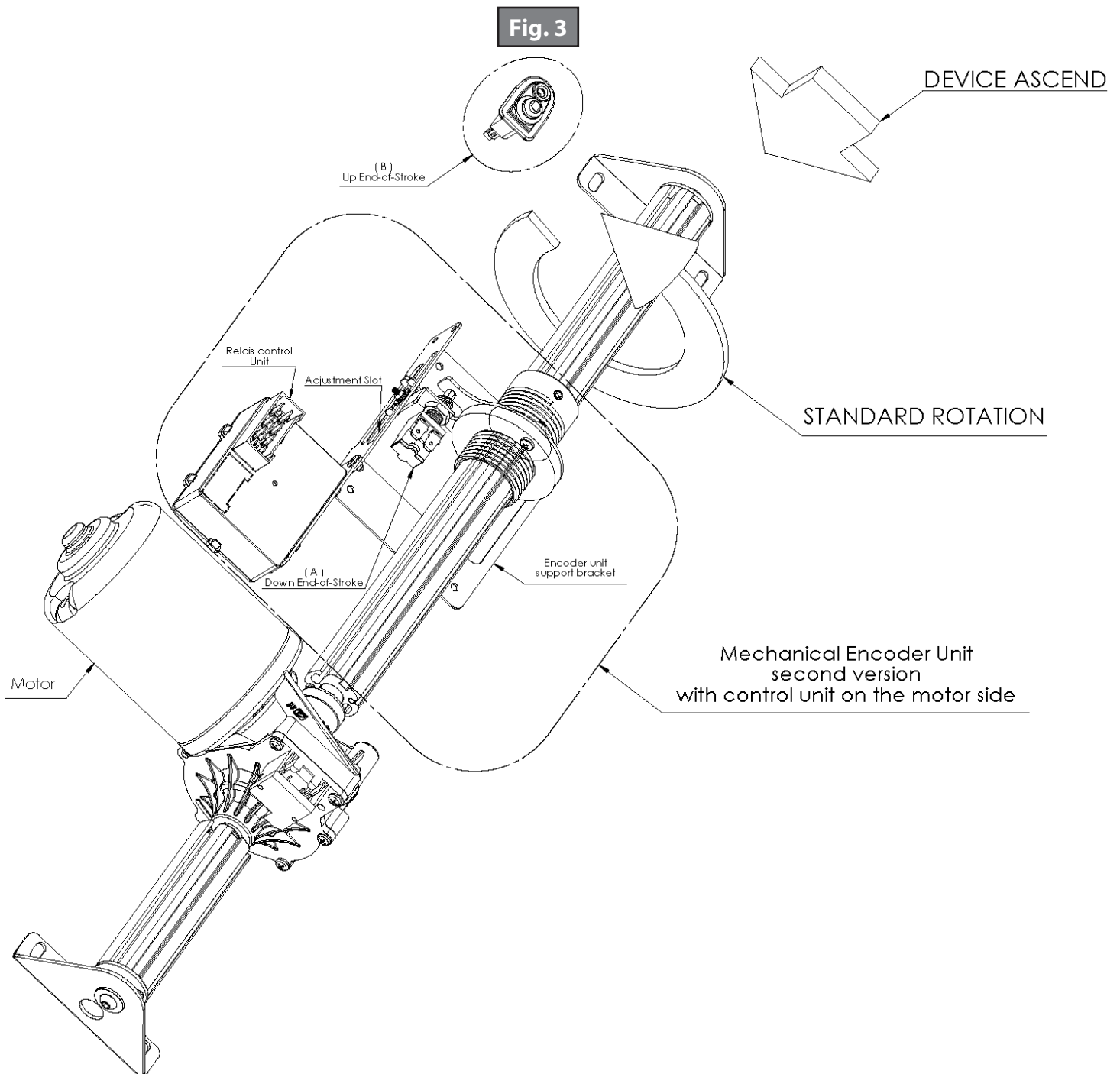

Fig. 4

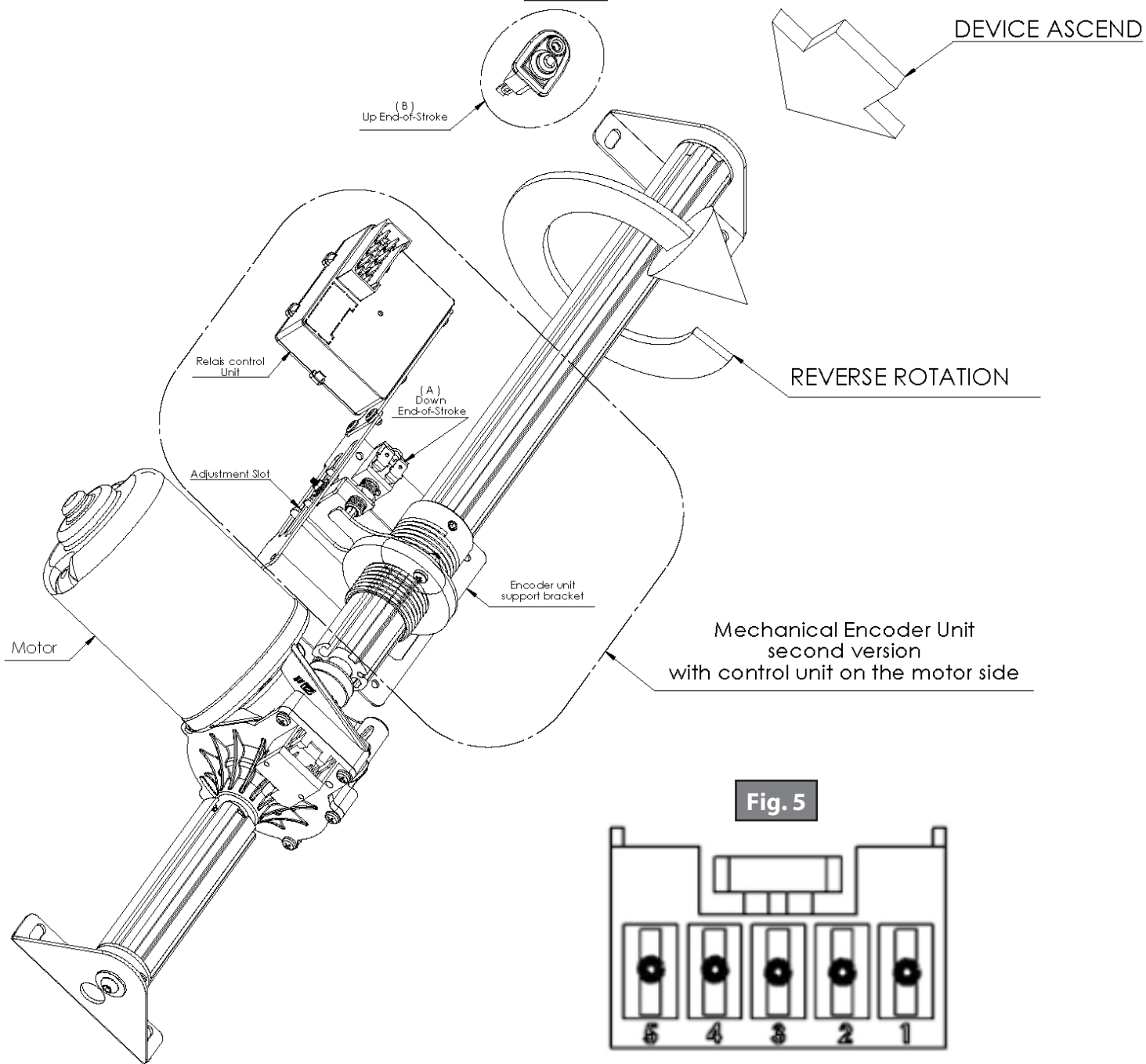
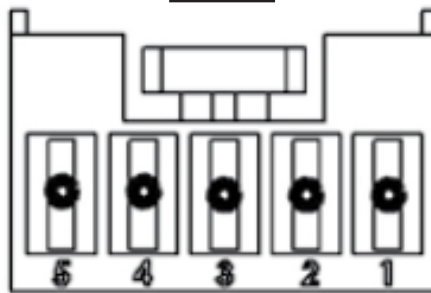

Fig. 5



Silkscreen Printing	Logic ID	Range	Clamps	Description
(C-3)	MOT2	DC 0-12 V	Pin 5	Motor (Grey)
	MOT1	DC 0-12 V	Pin 4	Motor (Brown)
		Not used	Pin 3	Not used
		Not used	Pin 2	Not used
		Not used	Pin 1	Not used

The motor has a 5-pole connector for a female movable connector represented in Fig. 6. The picture shows the connector from the cables connection side.

Wires No. 4 and 5 are motor connections, for the wiring please refer to diagram in Fig. 7.

Fig. 6

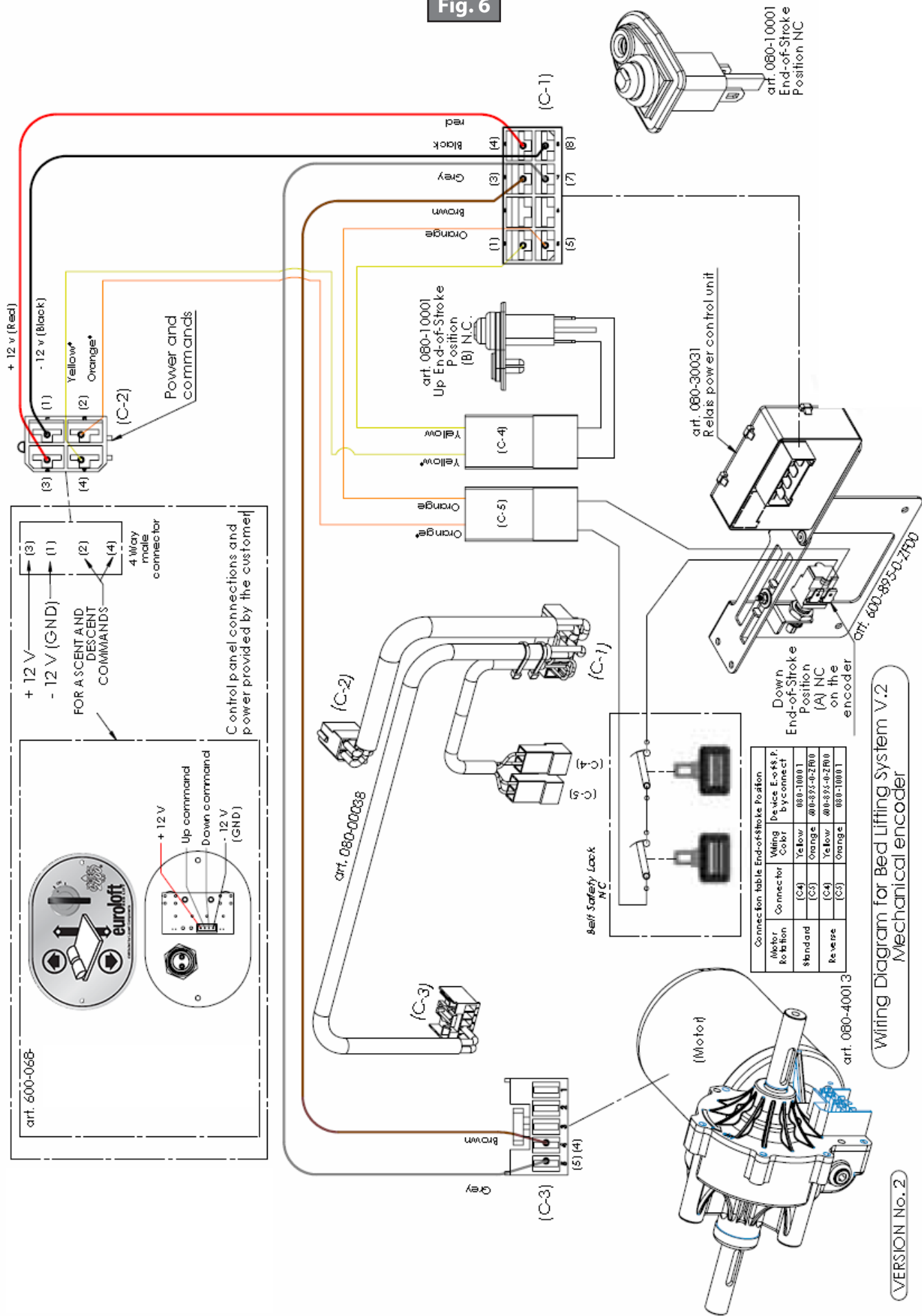

The diagram in Fig. 6 summarizes all of the connections between the board and the other items that should be established in order for the system to work correctly.

The motor connections (pin 3 and 7 of the 8-pole connector) and power connections (pins 4 and 8 of the 8-pole connector) must be carried out exactly as shown in the picture, be sure to use cables with a minimum section of $1\frac{1}{64}$ ".

Follow the instructions provided with the bed lifting system (wiring diagram).

Comply with current CEI regulations during the installation operation.

The Manufacturer provides a set of standard cables for installation with the bed lifting system. After electric installation it will be possible to start up and test the system.

The Manufacturer shall be held harmless for any bed lifting system malfunctioning caused by not having perfectly functioning electric system connections or to a wrong installation on the vehicle.

Fig. 7



The bed moves vertically in a specific structure developed to this purpose and its stroke is limited by two ends:

- On the upper side, the stroke is limited by an end-of-stroke sensor;
- On the lower side, the limit is represented by the lowest position set, by means of regulating the end-of-stroke located on the mechanical encoder.

The bed can be lifted or lowered through activation in "ON" position of the key switch located on the panel and by pressing the arrow-shaped switches on the front panel. When pressing the UP (arrow up) switch the bed will be lifted and it will go down when pressing the DOWN switch.

Two green LED-lights are located on the controller panel and they will simultaneously switch on. During movement of the bed, only the LED Corresponding to the direction of travel will be turned on.

The bed will be moving until you keep pressing the switch and it will stop when:

- The switch is released.
- A pre-set stop position is reached.
- The bed is being lifted and the end-of-stroke position is reached.

The bed will move by pressing one of the switches again, unless one of the following conditions is detected:

- The bed is in the end-of-stroke position and the UP switch is kept pressed.
- The bed is in the lower programmed position and the DOWN switch is kept pressed.

In these two situations the bed will not move because the pre-set end-of-stroke positions for operation are reached and it is not possible to overcome them.



When operating the bed lifting system, clear operation area of children and obstructions or death, serious injury or property damage could occur.

Security and Safety Devices

Unauthorized Access

The controller is equipped with a safety device to protect the system against unauthorized access, through activation in "ON" position of the key switch located on the panel (Fig. 8); with the key in position "OFF," the system is blocked.

Turn the key in "ON" position to unblock the protection and make the normal functions.

Warning Status for Safety Lock

While the vehicle is running the bed can be secured with specific belts in order to ensure safety conditions. The safety belts have an internal closed contact that can be used to differentiate between the status "safety belt fastened" and "safety belt not fastened". Tab. A and Tab B. (Page 19) show how to connect the belts, identified by the description "safety belts".

NOTE: Always block the bed on the highest limit before inserting the safety belt. The non observance of the rule could modify the lowest stop position

The different models have been designed and manufactured keeping in mind all the main standards of safety, to reduce and/or cancel any element of risk connected with the operation. In particular, it is important to point out the existence of the following safety devices:

Mechanical Devices - Bed lifting systems come with an unlocking device or MANUAL ACTIVATION device which makes it possible to operate the system manually; it is a crank device inserted in the motor (Tab. B, Page 19) that lifts and lowers the bed ONLY IN CASE OF EMERGENCY.

NOTE: Always disconnect from power before performing any operation on the bed lifting system.

Motor Protection System

The bed lifting system comes with a protection system for the electric motor against mechanical overload that could affect the motor while running.



Do not stand in the bed lifting system operation area.

It is strictly forbidden to operate the system while people are on it.

It is strictly forbidden to be on the bed lifting system while being operated.

Do not reach into the bed lifting system components while being operated.

The bed must be fixed to the safety belts.

The different models have been designed and developed so to reduce or eliminate risks related to squashing and shearing. Risks related to bed lifting system operation are, however, virtually eliminated by the weak squashing forces.

Start-Up and Testing

The product is delivered to the customer fully tested and ready for start-up. Start-up operations and product testing shall be carried out - once the system has been mounted on the vehicle - by specialized staff in order to reduce risks related to product start-up.

All start-up and testing operations shall be carried out by skilled and authorized staff.

Application Field and Purpose

The product shall only and EXCLUSIVELY BE USED for the purpose for which it was developed, namely lift and lower a bed frame inside of leisure vehicles.

The Manufacturer shall be held harmless for any possible damages due to improper, unskilled or unreasonable use.

The user shall comply with current safety regulation in force in the installation country and also to common sense rules and make sure regular maintenance is performed correctly.

The installer, user or maintenance technician shall inform the Manufacturer about any possible defects or deterioration that might compromise the original safety of the system.

In case of commercial components mounted on the product, the component manufacturers are liable; the customer is liable for authorized staff using the product.

Important Information

- Safety devices shall not be tampered with for any reason.
- It is strictly forbidden to be on the bed lifting system while being operated.
- Do not interfere with the bed lifting system while operated, neither with any objects nor with hands.
- Before starting the vehicle engine and driving, always make sure the bed lifting system is in its highest position and the safety belts are fastened (excluding garage bed).
- Do not operate the system improperly (e.g. with people on it).
- The bed lifting system shall only be used by adult and responsible staff.
- It is forbidden to use the bed lifting system while the vehicle is running.
- Do not move the bed lifting system if people or animals or items are around, under or on it.
- Always comply with the bed lifting system maximum load capacity, i.E. 880 lb in static conditions.
- Never lift weights that overcome the bed lifting system maximum load, i.E. 132 lb in dynamic conditions, people or animals are not included and they must not be on the bed when the system is operating.
- The bed lifting system must never be used while the vehicle is running.
- It is forbidden to start the bed lift system manually with disconnected wires from motor unit to control unit.
- Should the mechanism not work, do not use the bed and ask for assistance at the next service center.

Maintenance

In order to ensure safe use of the bed lifting system without problems and in safe conditions for the operators, it is COMPULSORY to follow the control and maintenance plan provided in this chapter.

Complying with regular maintenance norms - as well as monitoring the main bed lifting system components – is crucial to detecting any possible anomalies before they take place and necessary in order to avoid anomalies where and how necessary.

The different bed lifting system models have been designed and developed in such a way to reduce maintenance operations.

Maintenance Operations

Before starting maintenance operations, make sure the vehicle is parked and secured.

After ascertaining vehicle stability, disconnect the electric system of the bed lifting system from the vehicle battery.

1. Regular sight analysis of the belting and of the wall fastening elements (once a year)
2. Check-up of motor and shafts coupling (once a year)
3. Write on the "bed lifting system control register" (Annex 1, Page 20) the regular checks carried out and the number of cycles performed by the system detected by the control unit as described at point 8.2.6

NOTE: "Lifting mechanism control register" (Annex. 1, Page 20) the number of cycles done by the DEVICE and detected BY the control unit as described in point 7.8 of the installation manual - VALID ONLY FROM UPDATE FW 2.2.

It is however necessary to comply with the following general rules:

- Emergency and/or temporary repair operations shall never be carried out by unskilled and unauthorized staff.
- Keep the bed lifting system clean and tidy.
- Always preserve the bed lifting system completeness.

More complex operations shall be carried out by specialized staff.

Disassembling and Demolition

The Manufacturer designed and developed bed lifting systems having a life of at least 500 intermittent working hours, however only if the maintenance guidelines provided in this manual are complied with.

Disconnect the bed lifting electric system from the vehicle battery before starting disassembling procedures.

The bed lifting system main parts must be disassembled. Only operate with hand gloves and Individual Protection Devices (IPD) in order to avoid any possible squashing, shearing, cutting.

After finishing disassembling and sorting the components, hand them to authorized companies for disposal.

Disassembling and demolition operations shall be performed by skilled and authorized staff.

Bed lifting system components overhaul or replacement shall be carried out within a reasonable time of 36 months

A "control register" has been defined to this purpose (Annex I par. 4.4.2 line b) enabling the user to carry out periodical checks of the bed lifting system completeness in order to preserve safety conditions (ANNEX 1)

The manufacturer shall be held harmless in case any components or disassembled parts of the bed lifting system are recycled for use. Disposal of electric and electronic components:

Electric and electronic devices classified as waste pursuant to art. 6, par. 1, letter a) of the Legislative Decree of February 5th 1997, No. 22 and following modifications are defined as "Waste electrical and electronic equipment" or "WEEE", including all components, subgroups and consumables that are integral part of the product; an improper use of the equipment or part of the equipment can cause serious damage to environment and health due to the presence of hazardous materials contained. Pursuant to Legislative Decree 151/2005 it is therefore forbidden to dispose of WEEE as urban waste and it is necessary to collect WEEE separately. Fines shall otherwise be applied for illegal waste disposal pursuant to Legislative Decree of February 5th, 1997, No. 22. WEEE collection systems and "WEEE collection centers" have been defined by the public administration as areas, buildings and structures for separate collection and temporary stocking of WEEE, opened to citizens.

It is furthermore possible to return the system to the retailer when purchasing a new one.

The logo for separate collection of electrical and electronic equipment (EEE) is a crossed-out wheeled rubbish bin: this logo is printed directly on the product in a visible position and it is well readable and indelible (Fig. 8).

Fig. 8



General Information On Safety Regulations

All dangerous equipment such as shafts, pulleys, chains, crown gears, etc. have been isolated and protected - within structural limitations - with suitable protection panels.

The aforementioned panels, which effectively protect the user against dangerous components, shall not be removed, not even temporarily, and they shall be protected against interference throughout the bed lifting system life.

If it is necessary to remove the protections, the operator shall however follow safety instructions in order to protect him/herself and any other person in the operation area of the bed lifting system. Protections shall however be put back into place as soon as the maintenance operation is finished.

More specifically, it is necessary - while performing maintenance operations - to:

- Make sure the vehicle is parked and secured in safe and stable conditions before starting maintenance operations.
- Carry out each operation with the vehicle parked and only after disconnecting power.
- The bed lifting system must never be used while the vehicle is running.

Warranty Terms And Conditions

The Manufacturer "Project 2000" guarantees the bed lifting system components for 24 months after purchase. Defective parts shall not be tampered with and they shall be returned together with the serial number indicated on the plate located on the bed lifting system.

Parts that have been tampered with or partially disassembled will not be covered under warranty. Electronic control units will not be covered under warranty in case of incorrect connection detection to the system: in this case repair costs will be charged to the customer.

The Manufacturer "Project 2000" may decide to replace defective components instead of repairing them. Should replacement or repair have a negative outcome, the customer can charge repair costs to the Manufacturer or cancel the purchase.

Warranty won't be applied if the necessary periodic check ups, requested in this handbook, are not carried out and noted.

The manufacturer will not be liable for any indirect damage.

DAMAGES CAUSED BY IMPROPER USE OF THE BED LIFTING SYSTEM, OR USE NOT IN COMPLIANCE WITH THE INSTRUCTIONS PROVIDED IN THIS MANUAL, WILL NOT BE COVERED UNDER WARRANTY.

The warranty covers repair or replacement of parts at the Manufacturer's (Project 2000) premises. Transport costs (for spare parts under warranty) as well as retailer labor costs or other costs required by the user are not covered under warranty.

All disputes shall be subject to the jurisdiction of the court of Florence (Italy).

Tab. A

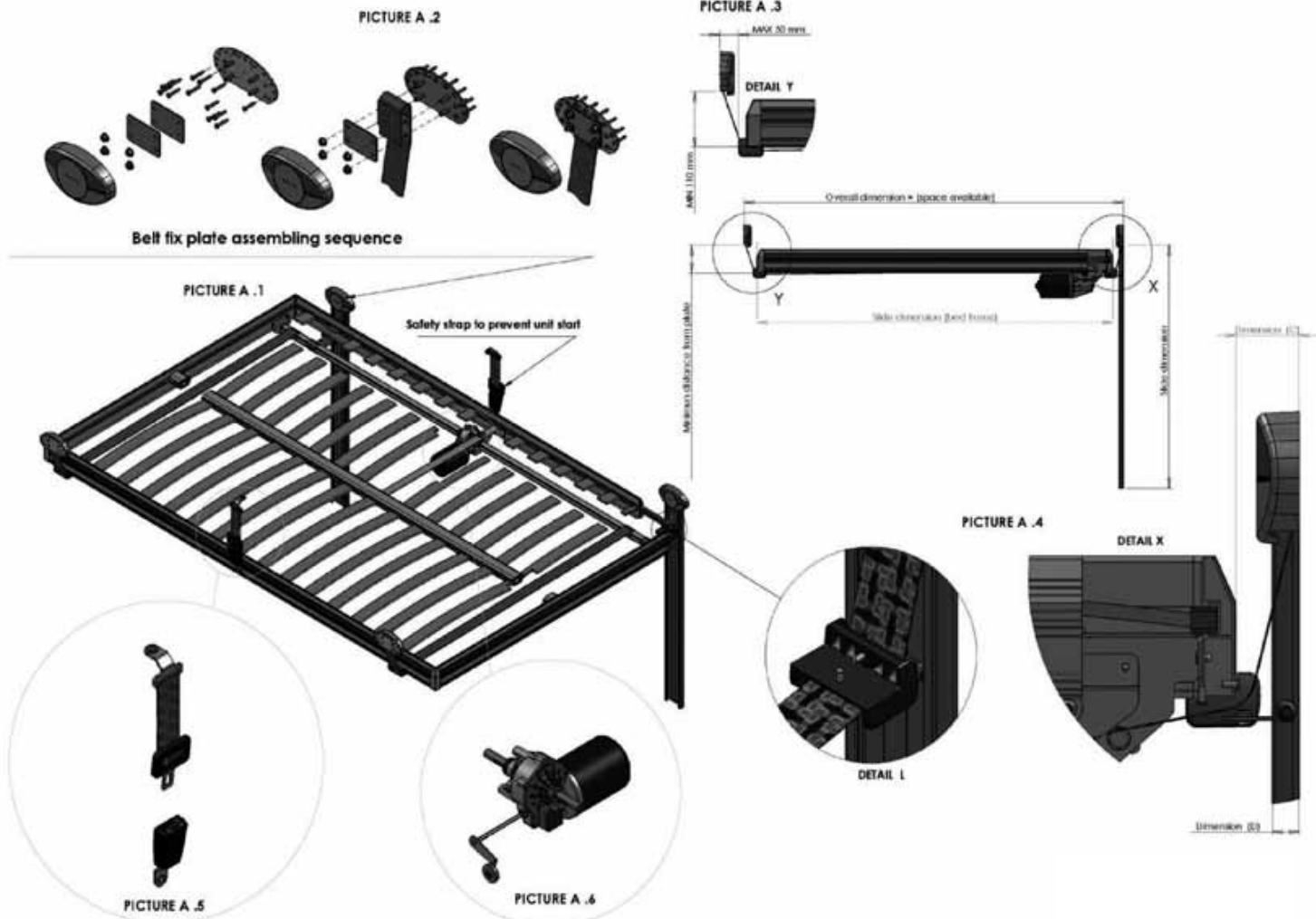

Tab. B

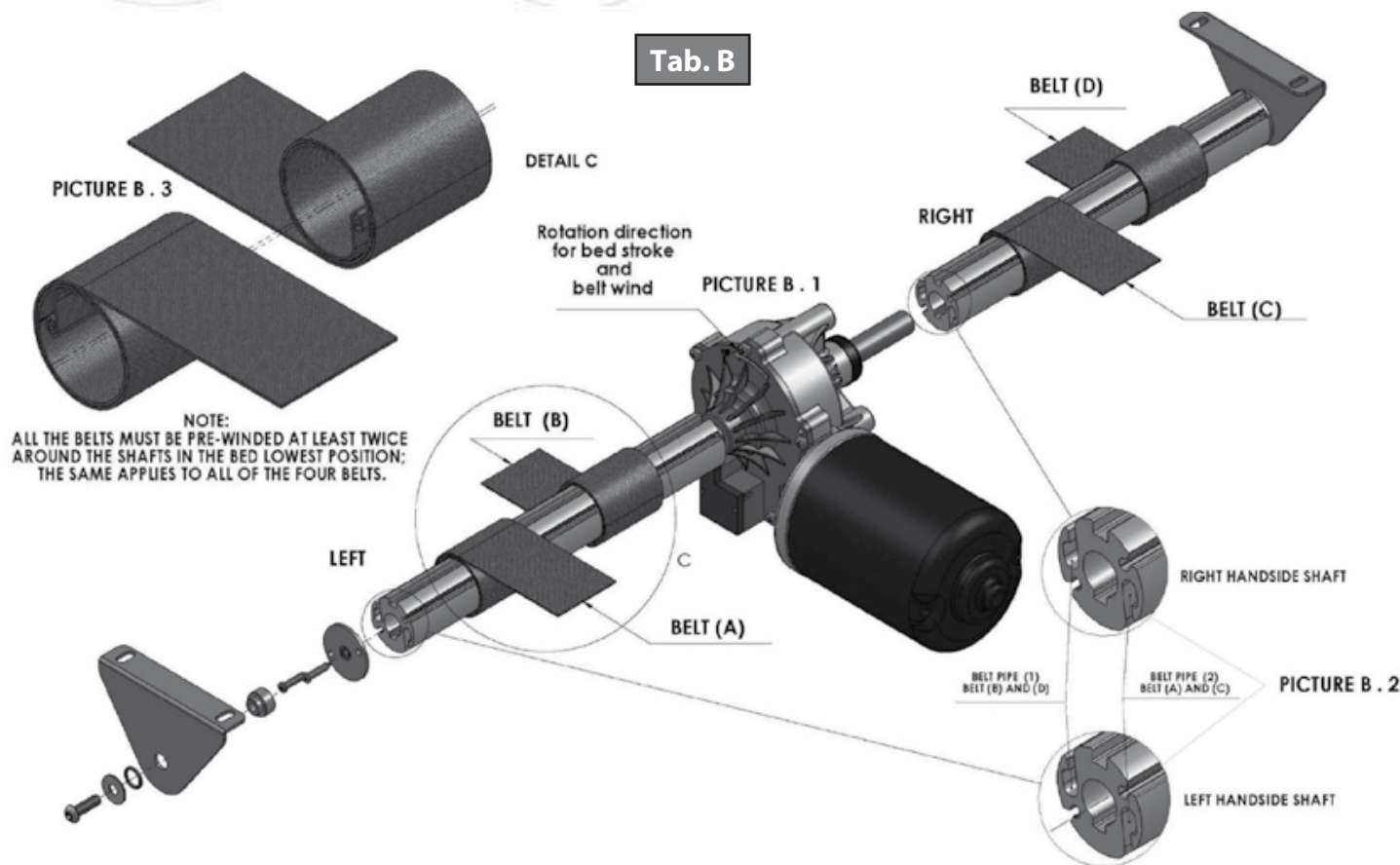

Bed Lift Maintenance Log

Bed Lifting System Control Register - Annex 1			
Device Type	Model	Serial Number	Manufacturing Year

Checks Performed	
Year _____	Year _____
Year _____	Year _____
Year _____	Year _____
Year _____	Year _____
Year _____	Year _____
Five Yearly Check _____	Five Yearly Check _____

Five Yearly Check Date _____ Number of Cycles _____	Yes	No
General check of the system by an authorized supplier.		
Eventual replacement of damaged pieces.		

NOTES: _____

Yearly Check Date _____ Number of Cycles _____	Yes	No
Are warning sound signals and lights working?		
Are the control devices for lifting and lowering the system working?		
Are the control devices for lifting and lowering the system clearly marked so that they can be correctly identified despite wear?		
Are there any clearances in the belt roller/s and the gear motor coupling?		
Is the gear motor perfectly working in all of its mechanical functions?		
Is the service breaking and parking system working?		
Are the bed lifting system belts undamaged and safely fastened?		
Are the general conditions of the system good?		
Is the system nominal maximum load still clearly and indelibly indicated?		
Is the system maximum load still clearly and indelibly indicated?		
Are the anchoring elements safely fixed to the roof?		
Are security belts well fitted and efficient?		
Are lifting and lowering only possible on the top and bottom part of the mechanical end-of-stroke stops?		
Is the system user's manual available?		

NOTES: _____

Yearly Check Date _____ Number of Cycles _____	Yes	No
Are warning sound signals and lights working?		
Are the control devices for lifting and lowering the system working?		
Are the control devices for lifting and lowering the system clearly marked so that they can be correctly identified despite wear?		
Are there any clearances in the belt roller/s and the gear motor coupling?		
Is the gear motor perfectly working in all of its mechanical functions?		
Is the service breaking and parking system working?		
Are the bed lifting system belts undamaged and safely fastened?		
Are the general conditions of the system good?		
Is the system nominal maximum load still clearly and indelibly indicated?		
Is the system maximum load still clearly and indelibly indicated?		
Are the anchoring elements safely fixed to the roof?		
Are security belts well fitted and efficient?		
Are lifting and lowering only possible on the top and bottom part of the mechanical end-of-stroke stops?		
Is the system user's manual available?		

NOTES: _____

Yearly Check Date _____ Number of Cycles _____	Yes	No
Are warning sound signals and lights working?		
Are the control devices for lifting and lowering the system working?		
Are the control devices for lifting and lowering the system clearly marked so that they can be correctly identified despite wear?		
Are there any clearances in the belt roller/s and the gear motor coupling?		
Is the gear motor perfectly working in all of its mechanical functions?		
Is the service breaking and parking system working?		
Are the bed lifting system belts undamaged and safely fastened?		
Are the general conditions of the system good?		
Is the system nominal maximum load still clearly and indelibly indicated?		
Is the system maximum load still clearly and indelibly indicated?		
Are the anchoring elements safely fixed to the roof?		
Are security belts well fitted and efficient?		
Are lifting and lowering only possible on the top and bottom part of the mechanical end-of-stroke stops?		
Is the system user's manual available?		

NOTES: _____

Yearly Check Date _____ Number of Cycles _____	Yes	No
Are warning sound signals and lights working?		
Are the control devices for lifting and lowering the system working?		
Are the control devices for lifting and lowering the system clearly marked so that they can be correctly identified despite wear?		
Are there any clearances in the belt roller/s and the gear motor coupling?		
Is the gear motor perfectly working in all of its mechanical functions?		
Is the service breaking and parking system working?		
Are the bed lifting system belts undamaged and safely fastened?		
Are the general conditions of the system good?		
Is the system nominal maximum load still clearly and indelibly indicated?		
Is the system maximum load still clearly and indelibly indicated?		
Are the anchoring elements safely fixed to the roof?		
Are security belts well fitted and efficient?		
Are lifting and lowering only possible on the top and bottom part of the mechanical end-of-stroke stops?		
Is the system user's manual available?		

NOTES: _____

Yearly Check Date _____ Number of Cycles _____	Yes	No
Are warning sound signals and lights working?		
Are the control devices for lifting and lowering the system working?		
Are the control devices for lifting and lowering the system clearly marked so that they can be correctly identified despite wear?		
Are there any clearances in the belt roller/s and the gear motor coupling?		
Is the gear motor perfectly working in all of its mechanical functions?		
Is the service breaking and parking system working?		
Are the bed lifting system belts undamaged and safely fastened?		
Are the general conditions of the system good?		
Is the system nominal maximum load still clearly and indelibly indicated?		
Is the system maximum load still clearly and indelibly indicated?		
Are the anchoring elements safely fixed to the roof?		
Are security belts well fitted and efficient?		
Are lifting and lowering only possible on the top and bottom part of the mechanical end-of-stroke stops?		
Is the system user's manual available?		

NOTES: _____



L I P P E R T C O M P O N E N T S™

The contents of this manual are proprietary and copyright protected by Lippert Components, Inc. ("LCI"). LCI prohibits the copying or dissemination of portions of this manual unless prior written consent from an authorized LCI representative has been provided. Any unauthorized use shall void any applicable warranty. The information contained in this manual is subject to change without notice and at the sole discretion of LCI. Revised editions are available for free download from www.lci1.com.

Please recycle all obsolete materials.

For all concerns or questions, please contact
Lippert Components, Inc.

Ph: (574) 537-8900 | Web: www.lci1.com | Email: warranty@lci1.com