

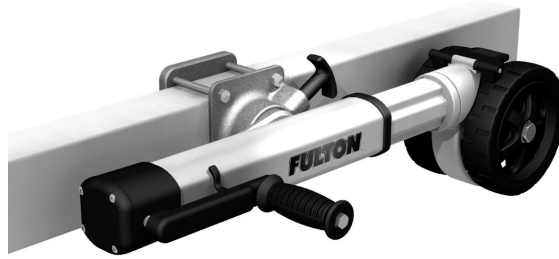

U.S. Patent # D568575, D570072, D571175 and Patents Pending



**Trailer Jack**



**Read, Understand, Follow and Save These Instructions**

Read, understand and follow all of these instructions and warnings (Instructions) before installing and using this product. Install and use this product only as specified in these instructions. Improper installation or use of this product may result in property damage, serious injury, and/or death. Never allow installation or use of this product by anyone without providing them with these instructions. You must read, understand and follow all instructions and warnings for any product(s) to which this product is used in conjunction with or installed. Save these instructions with the product for use as a reference for any future installation and use of the product.

**WARNING** Failure to follow all warnings and instructions may result in product failure, property damage, serious bodily injury, and/or death.

- This product must be installed and used in strict accordance with these instructions. Purchaser/owner must not alter or modify the product.
- Operator and bystanders should never position any part of body under or on the path of any portion of this product or the load being supported, or moved.
- Fully retract and rotate jack into its stowed position before towing.
- This product is not intended to be used as a transport device for the implement it is attached to. Minimize movement of implement while jack is under load.
- Do not allow children to play on or around this product or the load being supported, or moved.
- Secure the load, vehicle and trailer from rolling (by blocking wheels) when operating jack or coupling trailer.
- Never exceed maximum rated capacity. Refer to stamped markings or decals on product to obtain rated capacity. If uncertain, contact Cequent Trailer Products at 800-604-9466 or [www.cequentgroup.com](http://www.cequentgroup.com).
- These jacks are designed for vertical loading. Excessive side forces may cause jack failure and must be avoided.
- Before manually moving trailer, crank to lowest position.
- Lock the plunger pin into a hole in the mounting bracket before raising or lowering the tongue.
- These jacks are not designed for mounting to round tongues.
- Do not cut, drill, weld or modify this jack in any manner not described in these instructions.
- All welding must be performed by an AWS certified welder.
- Always replace bent, broken, or worn parts before using this product.

**Installation Instructions** Warning: Failure to follow all warnings and instructions may result in product failure, property damage, serious bodily injury, and/or death.

Before mounting the jack confirm that there will be no interference from the tow vehicle, tongue, ground, and any other mounted accessories while stationary or in motion. Before installing, check for interference in all positions including handle swing and swivel positions. Check for interference again after installation is complete. The height of the swivel mount is pre-set and torqued by the factory at a common height for most applications.

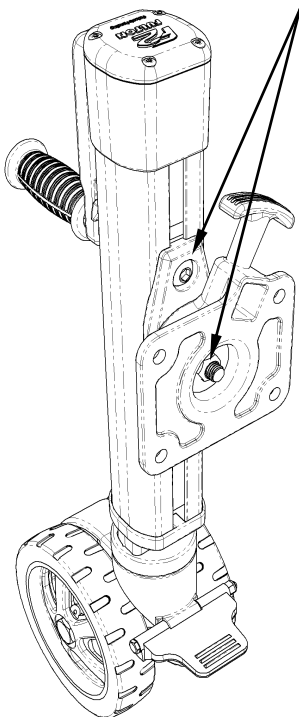

**Adjusting Swivel Mount Height: (if necessary)**

With jack removed from trailer, loosen the two swivel fasteners until the slide block moves freely along outer tube. To access the upper bolt, be sure the swivel bracket is rotated in the horizontal (3" mounting) position as shown. Adjust swivel mount to desired location and re-torque to 60-70 ft-lbs. After adjustment, check for proper swivel and pin engagement.

**Weld-on:**

**Mounting Plate is included on Weld-On models only.**

All welding must be performed by an AWS certified welder. Recheck the position of the mounting plate according to the precautions listed above and as shown in diagram below. Position the plate with the flat surface toward trailer. Align top of mounting plate flush with top of trailer tube and weld completely around using a 3/16" fillet weld. The threaded holes in the mounting plate may need to be masked for painting or re-tapped, depending on trailer finish requirements.

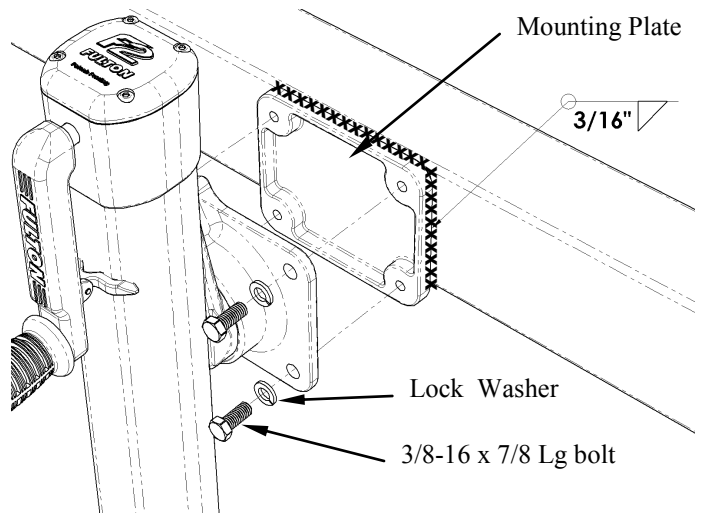

**MOUNTING POSITION FOR 3x5 TUBE**

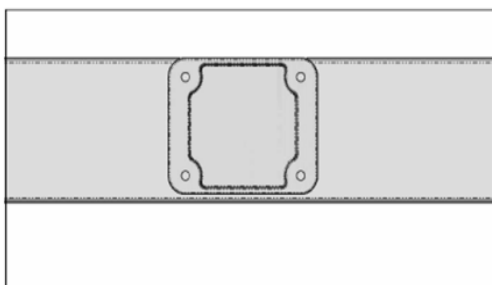

**MOUNTING POSITION FOR 3x4 TUBE**

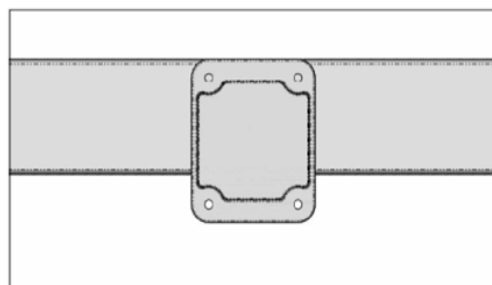

## Installation Instructions (Cont.)

### Bolt-on:

Available in 3"x 3", 3"x 4", or 3"x5" trailer tubes only. Position swivel bracket and U-bolts to allow proper mounting to trailer. Tighten nuts and torque to 20-25 ft.-lbs.

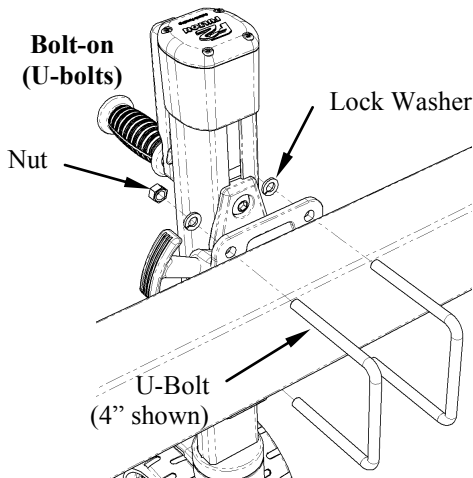

**Footplate:** Thread footplate into the bottom of the jack tube. Torque to 60-70 ft.-lbs.

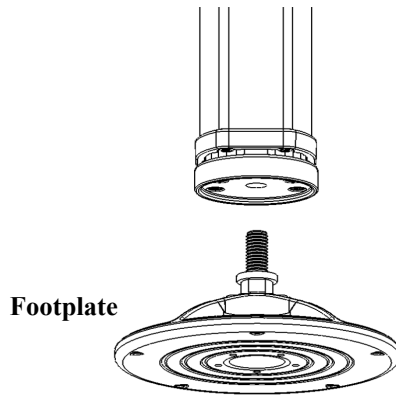

### Optional Wheel Wedge:

Assemble the optional Wheel Wedge as shown in the diagram below and torque to 6-9 in.-lbs. To activate, press downward until wedge locks into place. To release, lift up until pressure is released from wheels. Wheel Wedge is not intended to be a wheel brake or stop.

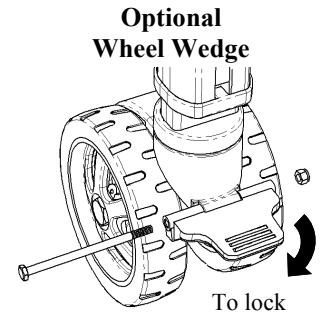

### Installing Handle Assembly:

Assemble handle assembly as shown and torque locknut to 20-25 in.-lbs.

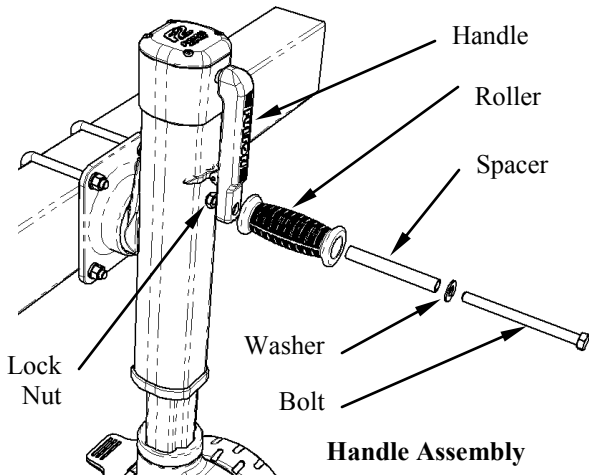

### Optional Handle Hold-Up:

To assemble, place Handle Hold-up with its stop block pointing toward top of jack. Center hold-up on handle and drive pin flush through hold-up & both tabs. Proper assembly allows Handle Hold-up to rotate down in the event of crank handle bypass.

### Optional Handle Hold-Up

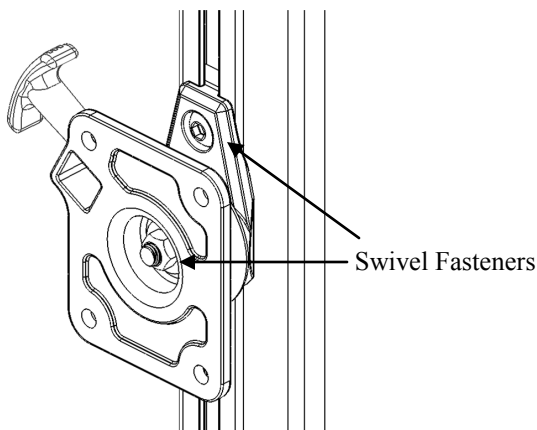
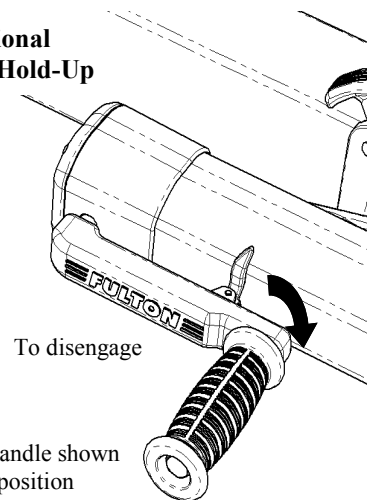

### Adjusting Swivel Mount Height (If Necessary):

With jack removed from trailer, loosen the two swivel fasteners until the slide block moves freely along outer tube. To access the upper bolt be sure the swivel bracket is rotated in the horizontal (3" mounting) position as shown. Adjust swivel mount to desired location and re-torque to 60-70 ft.-lbs. After adjustment, check for proper swivel and pin engagement.

## Maintenance

The F2 jack is designed with precision fit components and corrosion resistant materials to minimize the frequency of maintenance. Occasional cleaning with mild soap and water along with light oil lubrication of pivot points will prolong peak performance and appearance.

## Limited Lifetime Warranty

**Limited Lifetime Warranty ("Warranty").** Cequent Trailer Products, Inc. ("We" or "Us") warrants to the original consumer purchaser only ("You") that the product will be free from material defects in both material and workmanship, ordinary wear and tear excepted; provided that installation and use of the product is in accordance with product instructions. There are no other warranties, express or implied, including the warranty of merchantability or fitness for a particular purpose. This warranty is not transferable.

**Limitations on the Warranty.** This Warranty does not cover: (a) normal wear and tear; (b) damage through abuse, neglect, misuse, or as a result of any accident or in any other manner; (c) damage from misapplication, overloading, or improper installation; (d) improper maintenance and repair; and (e) product alteration in any manner by anyone other than Us, with the sole exception of alterations made pursuant to product instructions and in a workmanlike manner.

**Obligations of Purchaser.** To make a Warranty claim, contact Us at 1050 Indianhead Drive, Mosinee, WI 54455, 1-800-604-9466, identify the product by model number, and follow the claim instructions that will be provided. Any returned product that is replaced by Us becomes our property. You will be responsible for return shipping costs. Please retain your purchase receipt to verify date of purchase and that You are the original consumer purchaser. The product and the purchase receipt must be provided to Us in order to process Your Warranty claim.

**Remedy Limits.** Product replacement is Your sole remedy under this Warranty. We shall not be liable for service or labor charges incurred in removing or replacing a product or any incidental or consequential damages of any kind.

**Assumption of Risk.** You acknowledge and agree that any use of the product for any purpose other than the specified use(s) stated in the product instructions is at Your own risk.

**Governing Law.** This Warranty gives You specific legal rights, and You also may have other rights which vary from state to state. This Warranty is governed by the laws of the State of Michigan, without regard to rules pertaining to conflicts of law. The state courts located in Oakland County, Michigan shall have exclusive jurisdiction for any disputes relating to this Warranty.

47912 Haylyard Dr. Suite 100  
Plymouth, MI 48170 USA  
800/632-3290  
www.cequentgroup.com

